

**MANUAL – INSTALLATION, BALANCING + MAINTENANCE**

---

# **Therma-Fuser™**

TL Series

v001 – Issue Date: 10/26/22

© 2022 Acutherm. All rights reserved.



# THERMA-FUSER™

---

## TABLE OF CONTENTS

Installation Instructions.....	1
System Balancing.....	3
Adjusting Temperature Setpoint (TL-C and TL-CW).....	4
Maintenance, Controlling the System & Minimum Flow .....	6
Trouble Shooting.....	6
Ten Year Warranty.....	8

# THERMA-FUSER™

## INSTALLATION INSTRUCTIONS

### Damaged Freight Claim Procedure

When the diffusers are received, inspect for damage which may have occurred during shipment. If damage is evident, it should be noted on the carrier's freight bill. A written request for inspection by the carrier's agent should be made at once.

### Storage

Cartons should always be stacked on end. Do not stack cartons flat on their sides. Excessive weight may cause damage to the diffusers. Do not store for prolonged times at temperatures exceeding 130°F/56°C.

### Identification

Units are factory shipped two per carton. The model designation is on the unit and on the carton. See **Fig. 2** on page two.

### Installation Precautions

When installing units, make sure construction debris does not enter units or duct system. Because models TL-C and TL-CW control room temperature by sensing the room air induced up the center of the room, care should be taken not to disturb room air induction and entrainment. For example, when located next to walls or dropped lights, air blown toward them results in the reflection of primary air back at the Therma-Fuser diffuser and should be avoided.

### Installation Instructions

1. Inspect the carton for damage before opening. Notify carrier if external damage exists. Submit all claims for shipping damage to the carrier.
2. Move diffusers (in cartons) to installation area. Note unit identification.
3. Remove cardboard box and cardboard insert. Discard packaging material. Model TL-C and TL-CW have factory installed balancing stops which hold the blade(s) open. See **Fig. 5**. Do not remove those stops until after balancing.
4. Install in ceiling grid. Install T-bar support wire close to each corner of unit. Make sure that only wire suspended T-bars are used to support unit weight. The diffuser can be hung with hanging holes in the top of the diffuser. See **Fig. 3**. Do not block the induction nozzle on the control panel end of the diffuser. Do not use screws or drill holes in the areas marked "No Holes or Screws" on the control panel end of the diffuser.
  - a. Do not install standard model TL-C and TL-CW linear Therma-Fuser units end-to-end. A 2 in. / 51mm clear space is required beyond the induction air outlet. For end-to-end installations, use continuous look (model TLC-XX) linear Therma-Fuser units.
  - b. Where ceiling tiles lay directly on the longitudinal edges of the diffuser, the longitudinal edges of the diffuser should be in the same place as the T-bars. Loosen the screws holding the end angles, raise the end angles and retighten the screws. The end angles will rest on the T-bars with the longitudinal edges in the plane of the T-bar bottoms. See **Fig. 4** on page three.
5. Connect and secure the supply duct to the collar. Flexible duct should NOT be formed in a centerline radius of less than 1½ times the duct diameter.)
6. Do NOT reset the temperature set point on the TL-C and TLCW models until the space is occupied. It is factory preset for average conditions (74°F / 23°C).
7. Balance the system. See **System Balancing**.
8. After the air conditioning system is started and **after the space is occupied**, where necessary adjust the temperature set point on ST-C and ST-HC models to suit the occupant. See **Adjusting Temperature**.

**FIG. 3 HOLES FOR HANGING** ▼

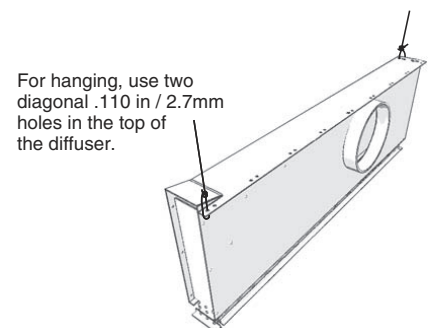

# THERMA-FUSER™

## INSTALLATION INSTRUCTIONS

### Models TL-C, TL-CW, TL-D and TL-RAD

FIG. 1 DIMENSIONS ▼

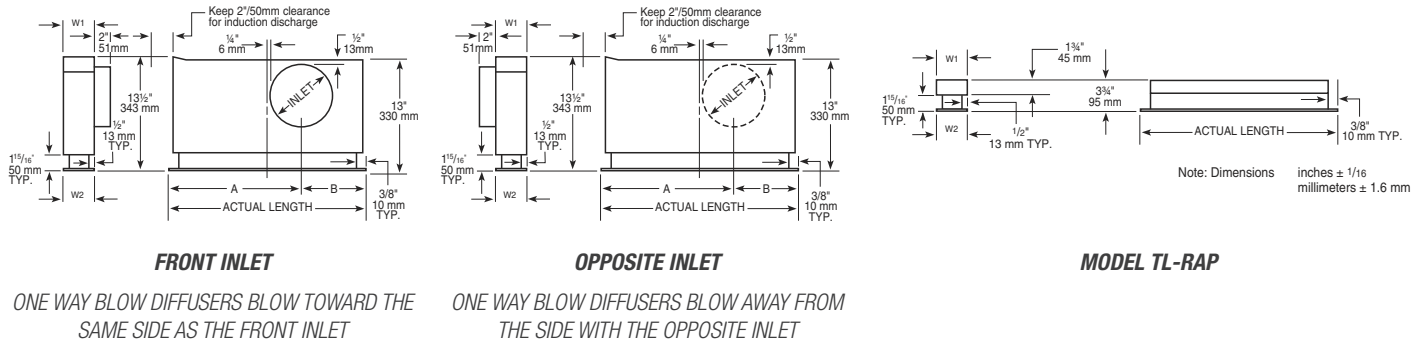

### One and Two Slot

Length Designation	Actual Length *	Inlet	A	B	W1	W2		
						1 Slot 1 Way	2 Slot 1Way	2 Slot 2 Way
24	23 3/4 in. 603 mm	5 7/8 in. 150 mm	15 1/16 in. 382 mm	8 1/16 in. 221 mm	4 in. 102 mm	2 9/16 in. 65 mm	3 3/4 in. 95 mm	4 in. 102 mm
36	35 3/4 in. 908 mm	5 7/8 in. 150 mm	21 1/16 in. 535 mm	14 1/16 in. 373 mm	4 in. 102 mm	2 9/16 in. 65 mm	3 3/4 in. 95 mm	4 in. 102 mm
48	47 3/4 in. 1213 mm	7 7/8 in. 200 mm	28 1/16 in. 713 mm	19 1/16 in. 500 mm	4 in. 102 mm	2 9/16 in. 65 mm	3 3/4 in. 95 mm	4 in. 102 mm
60	59 3/4 in. 1518 mm	7 7/8 in. 200 mm	34 1/16 in. 865 mm	25 1/16 in. 653 mm	4 in. 102 mm	2 9/16 in. 65 mm	3 3/4 in. 95 mm	4 in. 102 mm

### Four Slot

Length Designation	Actual Length *	Inlet	A	B	W1	W2	
						2 Slot 1Way	2 Slot 2 Way
24	23 3/4 in. 603 mm	7 7/8 in. 200 mm	15 1/16 in. 382 mm	8 1/16 in. 221 mm	6 5/16 in. 160 mm	6 in. 153 mm	6 3/8 in. 162 mm
36	35 3/4 in. 908 mm	7 7/8 in. 200 mm	21 1/16 in. 535 mm	14 1/16 in. 373 mm	6 5/16 in. 160 mm	6 in. 153 mm	6 3/8 in. 162 mm
48	47 3/4 in. 1213 mm	9 7/8 in. 250 mm	28 1/16 in. 713 mm	19 1/16 in. 500 mm	6 5/16 in. 160 mm	6 in. 153 mm	6 3/8 in. 162 mm
60	59 3/4 in. 1518 mm	11 7/8 in. 300 mm	34 1/16 in. 865 mm	25 1/16 in. 653 mm	6 5/16 in. 160 mm	6 in. 153 mm	6 3/8 in. 162 mm

\* 595, 895, 1195 and 1495 mm lengths are available to fit metric ceilings.

† Oval shaped inlet

FIG. 2 MODEL DESIGNATION ▼

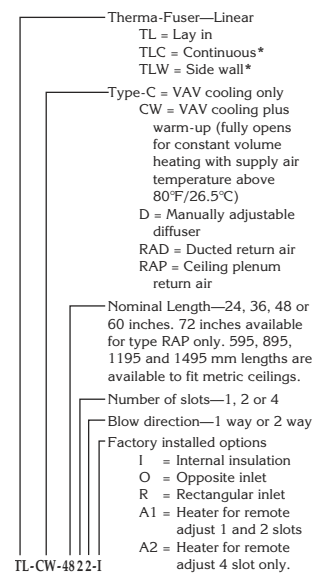

\* See separate dimensions and separate instructions for models TLC-XX and TLW-XX.

# THERMA-FUSER™

## SYSTEM BALANCING

VAV systems are balanced for design air volume at maximum air flow and systems using Therma-Fuser VAV diffusers are no exception. When all the Therma-Fuser diffusers are set for maximum air flow by fully opening them, the system is really a constant air volume system and is balanced as a constant volume system. Balancing dampers are best located at the takeoff before the runout to the Therma-Fuser diffuser.

1. Prepare the system for balancing. (Make necessary checks for diversity, fan capacities, fan rotation, minimum outside air requirements, duct leaks and static pressure controller design settings. Set outside air control damper for minimum air and return air control damper for maximum air.)
2. Make sure Therma-Fuser diffusers are open. TL-C and TL-CW models are shipped with balancing stops in position to hold the blade(s) wide open. The stops are a wedge which should be wedged between the foam side of the blade and the curved aluminum piece (pushing the blade so that its back is in contact with the vertical aluminum piece). See **Fig. 5**. For multiple blade units, all blades must be wedged open for proper balancing.
3. Start fans, adjust system for 100% air flow and make system checks. (Measure static pressure across filters and coils and at sensor for static pressure controller. Measure supply, return and branch duct air flow.)
4. Measure air flow from each Therma-Fuser diffuser and adjust damper at the duct takeoff to obtain design air volume. Air volume measurement may be made with a direct reading balancing hood or air velocity meter. If a velocity meter is used, the velocity is measured in the outside slot on the same side as the duct connection 2 in. / 51mm from either end of the blade at the opening between the outside blades and the curved aluminum piece. See **Fig. 6**. The  $A_k$  factors for the different linear lengths are shown in Table 1. Multiply the velocity in fpm times  $A_k$  in  $ft^2$  to get air flow in cfm.
5. Return Therma-Fuser diffusers to operating condition. Remove balancing stops by grabbing the looped end and pulling straight down from the face.
6. Return the remainder of the system to operating condition.

**Table 1.  $A_k$  factors in  $ft^2$  for TL Therma-Fuser diffusers fully open.**

Type	$A_k$	Type	$A_k$	Type	$A_k$
TL-2411	0.07	TL-2422	0.14	TL-2421	0.12
TL-3611	0.11	TL-3622	0.18	TL-3621	0.20
TL-4811	0.14	TL-4822	0.26	TL-4821	0.28
TL-6011	0.22	TL-6022	0.28	TL-6021	0.32
TL-2411	0.31	TL-2422	0.30		
TL-3641	0.42	TL-3642	0.39		
TL-4841	0.60	TL-4842	0.55		
TL-6041	0.70	TL-6042	0.65		

**FIG. 4 END ANGLE RAISED SO THAT LONGITUDINAL EDGES ARE IN THE PLANE OF THE T-BARS** ▼

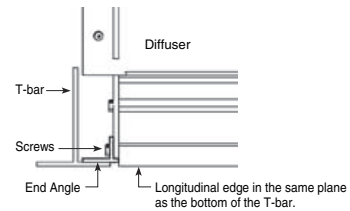

**FIG. 5 BALANCING STOPS** ▼

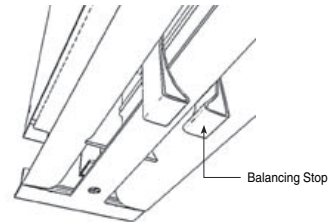

**FIG. 6 LOCATION OF VELOMETER** ▼

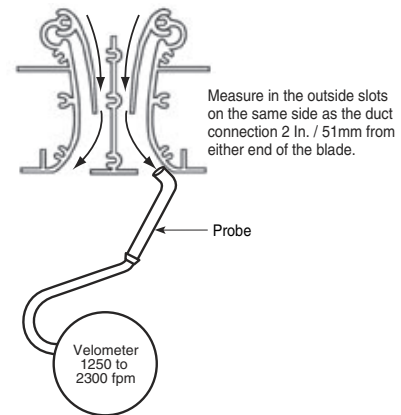

### BALANCING (TL-D)

1. The damper blade opening is factory set. Readjust where necessary by turning the adjusting screw. See **Fig. 7**.
2. Place a direct reading diffuser balancing hood over the face of each TL-D diffuser

# THERMA-FUSER™

## ADJUSTING TEMPERATURE SETPOINT (TL-C AND TL-CW)

FIG. 4 MEASURING VELOCITY ▼

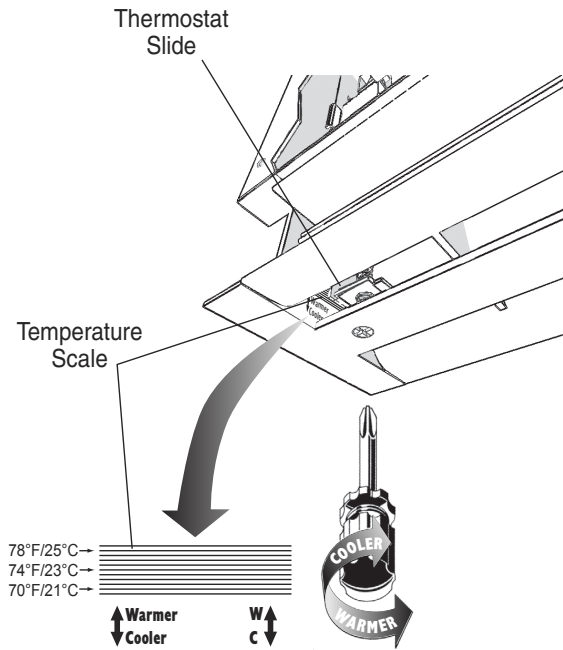

Read the temperature set point at the bottom of the thermostat slide.

### Adjusting Minimum Flow

The room temperature set point is adjusted by turning the phillips screw with a phillips screwdriver to move the thermostat slide up or down. Four slot units have two thermostats, each controlling two slots, which are separately adjusted. The temperature scale, located behind the thermostat slide, can be viewed at the end of the diffuser slot. Each graduation on the temperature scale is 1°F/.53°C providing an easy way of determining the amount of adjustment. Turning the phillips screw clockwise will move the slide down over the temperature scale for a cooler set point. Turning the phillips screw counterclockwise moves the thermostat slide up to a warmer setpoint. About 1½ turns will change the setpoint by 1°F/.53°C.

The diffuser is factory set to maintain approximately 74°F/23°C. It is not necessary to adjust the temperature set point at time of installation. Instead, make any adjustments after the system has been started and the space is occupied. Then adjust only those Therma-Fuser difusers where occupants are uncomfortable at the factory set point.

Readjust to the factory set point by turning the phillips screw clockwise (cooler set point) until the thermostat slide hits the stop. Then turn counter clockwise (warmer) for nine turns.

### Recommended Adjustments For Various Conditions

Mode	Room Temp.	Blade Position	Recommended Action
Cooling	Too Cold	Open	Adjust for higher room temperature set point.
		Closed	Therma-Fuser diffuser is correct. Check if cooling is still required, and if not, turn cooling unit off.
TL-C TL-CW	Too Warm	Open	Therma-Fuser diffuser is correct. Check for lack of air or for too warm air temperature.
		Closed	Adjust for lower room temperature set point.
Too Noisy	Any	Any	Reduce static pressure. Recommended static pressure is .05 to .25 in. wg / 12 to 62 Pa at the inlet of the diffuser.

# THERMA-FUSER™

## MAINTENANCE, CONTROLLING THE SYSTEM & MINIMUM FLOW

### Maintenance

The moving parts of the TL Therma-Fuser diffuser have no maintenance or lubrication requirements. We are often asked to recommend periodic maintenance procedures and a spare parts stock. Recommended maintenance is to clean the outer surfaces of the Therma-Fuser diffuser—nothing else. We do not recommend stocking any spare parts. Our customers also confirm that stocking is unnecessary.

### Controlling the System (TL-C and TL-CW)

References:

- System Design, p 5, TL brochure, Form 21.1.
- Chapters 2.2, 3.1 and 3.2, pp 6, 7 and 8, Designing Modular VAV Systems, Form 5.2.
- Air Handling and Fan Coil Units Subzoned with Therma-Fuser VAV modules, Form 6.7.
- DX Equipment Zoned with Therma-Fuser VAV Modules, Form 6.5.

### Supply Air Temperature

The source of cooling is controlled from supply air temperature. As with all VAV systems, the goals are to achieve a **constant** supply air temperature (may be reset to another constant supply air temperature) and to limit the supply air temperature. Limits for supply air temperature should be between 50°F/10°C and 68°F/20°C. These objectives are best achieved by modulating chilled water valves, and other variable equipment from supply air temperature. On/off equipment such as DX compressors are cycled from supply air temperature. Use a discharge air sensor for the supply air temperature signal.

For TL-CW models, mode change between heating, recirculation and cooling is controlled from room temperature. Signals from one or more room temperature sensors may be used for mode change. When using more than one sensor, a “majority rules” approach is recommended. Constant volume heating temperature for TL-CW models should be as low as possible but no lower than 80°F / 26.5° C.

### Static Air Pressure

As with all VAV systems, the fan must run continuously during occupied times. Goals of static pressure control are to provide enough static pressure to obtain the required air volume especially at the diffuser farthest from the fan, to avoid diffuser noise by limiting static pressure at both full flow and turndown and to provide pressure independence or consistent operation as the system flow changes.

These objectives can be achieved with the usual methods of automatic static pressure control: bypass dampers, discharge dampers, zone dampers, and fan control (variable speed drives, inlet dampers, etc.). Locate the static pressure sensor as far down the duct as possible—at least 2/3 down the duct from the first takeoff.

### MINIMUM FLOW (TL-C and TL-CW)

Standard TL units have a 10% leakage. To obtain higher minimum flows, a shorter length of blade gasket (foam) for each blade can be factory installed or it can be field removed per the table below. The blade gasket must be removed at the end opposite from the induction slot.

#### Amount of Gasket to be Removed from each Blade

Length Designation	Minimum Flow as a % of Maximum Flow	
	20%	30%
24	5 in. / 128 mm	10 in. / 254 mm
36	8 in. / 204 mm	11 in. / 280 mm
48	11 in. / 280 mm	16 in. / 407 mm
60	14 in. / 356 mm	28 in. / 712 mm

# THERMA-FUSER™

## TROUBLE SHOOTING

Trouble shooting Therma-Fuser diffusers requires looking at the system as a whole. Before examining the Therma-Fuser diffuser for failure it is worth the time to be sure the system is functioning properly and that something has not been overlooked. Before calling Acutherm, please complete the data log for all Therma-Fuser diffusers to be evaluated.

### System Check

The system should be:

1. Delivering 50°- 68°F/10° - 20°C supply air when in the cooling mode.
2. Delivering 80°-120°F/26.5° – 49°C supply air when in the heating mode. (TL-CW only)
3. Maintaining static pressure at the inlet to each Therma-Fuser diffuser between .05 and .25"wg/12 and 62 Pa.
4. Maintaining continuous fan operation during occupied hours.

### Therma-Fuser Diffuser Check List

Once the above checks have been completed, examine **and record** the following (conditions may vary over time; several measurements at different times may be required):

1. Room temperature 4 ft / 1.2 m above the floor directly under the Therma-Fuser diffuser.
2. Supply air temperature at the inlet of the Therma-Fuser diffuser.
3. Static pressure at the inlet of the Therma-Fuser diffuser.
4. Cooling setpoint(s). **See Fig. 7.** Read the cooling setpoint(s) by counting the lines from the bottom of the scale to the bottom of the slider.
5. Blade opening(s). Look into the diffuser slot and observe the blade position. Is it fully closed, fully open or part way between? Is the gasket installed on the full length of each blade?
6. If possible, measure air flow with a flow hood or measure air velocity as shown in **Fig 6.**
7. Are the ends of the diffusers at least 2 in. / 50 mm apart?
8. Is construction or other debris clogging the perforated plate in the inlet?



# THERMA-FUSER™

## TROUBLE SHOOTING

### Trouble Shooting Data Log

Location	Type Diffuser		Date	Time	Room Temp	S.A. Temp	Duct S.P.	Set Point(s)	Blade Opening	Air Flow
	Length	No. Slots								

# THERMA-FUSER™

---

## TEN YEAR WARRANTY

Acutherm warrants that its Therma-Fuser diffusers, exclusive of any options and accessories (whether factory or field installed) shall be free from defects in material or workmanship for a period of ten (10) years from the date of shipment and agrees to repair or replace, at its option, any parts that fail during said ten (10) year period due to any such defects which would not have occurred had reasonable care been taken, provided that such parts have been inspected by Acutherm and found defective and provided the diffusers have been given normal and proper usage and all parts and controls remain unaltered. Acutherm makes **NO WARRANTY OF MERCHANTABILITY OF PRODUCTS OR OF THEIR FITNESS FOR ANY PURPOSE OR ANY OTHER EXPRESS OR IMPLIED WARRANTY WHICH EXTENDS BEYOND THE LIMITED WARRANTY ABOVE. ACUTHERM'S LIABILITY FOR ANY AND ALL LOSSES AND DAMAGES RESULTING FROM DEFECTS SHALL IN NO EVENT EXCEED THE COST OF REPAIR OR REPLACEMENT OF PARTS FOUND DEFECTIVE UPON EXAMINATION BY ACUTHERM. IN NO EVENT SHALL ACUTHERM BE LIABLE FOR INCIDENTAL, INDIRECT OR CONSEQUENTIAL DAMAGES OR DAMAGES FOR INJURY TO PERSONS OR PROPERTY.** Acutherm shall not be responsible for freight to or from its plant in connection with the inspection, repair or replacement of parts under the terms of this limited warranty nor for cost or installation.



---

This document contains the most current product information as of this printing.  
For the most up-to-date product information, please go to [acutherm.com](http://acutherm.com)

© 2022 Acutherm. All rights reserved.

