



MANUAL – INSTALLATION, BALANCING + MAINTENANCE

THERMA-FUSER

TF Series

v001 – Issue Date: 09/22/22

© 2022 Acutherm. All rights reserved.



THERMA-FUSER

TABLE OF CONTENTS

| | |
|-------------------------------------------------|----|
| Installation Instructions..... | 1 |
| Balancing | 3 |
| Adjusting Temperature..... | 5 |
| Blow Patterns (TF-C, TF-CW, and TF-HC) | 6 |
| Maintenance..... | 7 |
| Controlling the System..... | 6 |
| Trouble Shooting (TF-C, TF-CW, and TF-HC) | 8 |
| Ten Year Warranty..... | 10 |

THERMA-FUSER

INSTALLATION INSTRUCTIONS

Damaged Freight Claim Procedure

When the diffusers are received, inspect for damage which may have occurred during shipment. If damage is evident, it should be noted on the carrier's freight bill. A written request for inspection by the carrier's agent should be made at once.

Storage

Cartons should always be stacked on end with the arrows on the cartons pointing up. Do not stack cartons flat on the sides. Excessive weight may cause damage to the diffusers. Do not store for prolonged times at temperatures exceeding 130°F/56°C.

Identification

Diffusers are factory shipped one per carton. The model designation is on the diffuser and on the carton.

Installation Precautions

When installing diffusers, make sure construction debris does not enter the diffuser or duct system.

Because the models TF-C, TF-CW and TF-HC control room temperature by sensing the room air induced up the center of the room, care should be taken not to disturb room air induction and entrainment. For example, location next to walls or dropped lights results in the reflection of primary air back at the Therma-Fuser diffuser and should be avoided. A three-way blow Therma-Fuser diffuser should be used in this instance if either the light or the Therma-Fuser diffuser cannot be relocated.

Installation Instructions

1. Inspect the carton for damage before opening. Notify carrier if external damage exists. Submit all claims for shipping damage to the carrier.
2. Move diffusers (in cartons) to installation area. Note unit identification.
3. Remove cardboard box and cardboard insert. Discard packing material.
4. If other than 4 way blow pattern is factory installed, note the "AIRFLOW" markings on the top of the diffuser and locate those sides in the proper direction.
5. Install in ceiling grid. Install T-bar support wire close to each corner of diffuser. Make sure that only wire suspended T-bars are used to support diffuser weight. (Adaptor frames are available for other than lay in ceilings.)
6. Connect and secure the supply duct to the collar. Flexible duct should NOT be formed in a centerline radius of less than 1½ times the duct diameter. Improper installation may result in different performance from published ratings.
7. Do NOT reset the temperature set point on the TF-C, TF-CW and TF-HC models until the space is occupied. It is factory preset for average conditions (74°F/23°C).
8. Balance the system. See **Balancing**.
9. After the air conditioning system is started and **after the space is occupied**, where necessary adjust the temperature set point on TF-C, TF-CW and TF-HC models to suit the occupant. See **Adjusting Temperature**.

Operating Instructions

Operating instructions for models TF-C, TF-CW and TF-HC are located on the back of the appearance panel.

FIG. 1 DIMENSIONS TF-C, TF-CW, TF-HC, TF-D AND TF-RA ▼

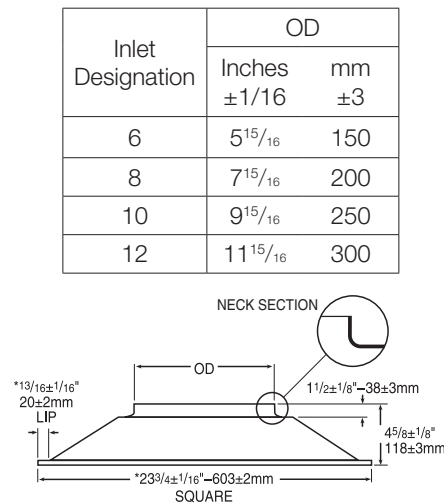

*595±2MM SQUARE WITH 16±2MM LIP AVAILABLE—SPECIFY 595MM SQUARE.

THERMA-FUSER

INSTALLATION INSTRUCTIONS

Opening the Appearance Panel (TF-C, TF-CW, TF-HC, TF-D)

The appearance panel is attached with a latch clip on one side and hinges on the opposite side.

To open the appearance panel (on a Therma-Fuser diffuser installed in the ceiling):

1. Locate the side of the Therma-Fuser diffuser with the thermostat(s). Using two hands, one on each side of the latch clip bracket, place your fingers above the appearance panel and firmly pull down to disengage the clip. The appearance panel will rotate and hang down vertically on the hinges.

To close the appearance panel:

1. Rotate the panel upward.
2. Latch the panel by pushing the clip into the small square hole in the bracket.

To remove the appearance panel:

1. Open appearance panel as described above.
2. Rotate the appearance panel away from the latch clip bracket to force the hinge hooks open on the panel.
3. Slightly lift the panel to remove from the hinges.

To reattach the appearance panel:

1. Hang the appearance panel on the hinges.
2. Press the hinge hooks against the panel to close around the hinge brackets.
3. Close panel as describe above.

THERMA-FUSER

BALANCING

BALANCING (TF-C, TF-CW AND TF-HC)

VAV systems are balanced for design air volume at maximum air flow and systems using Therma-Fuser VAV diffusers are no exception. When all the Therma-Fuser diffusers are set for maximum air flow by fully opening them, the system is really a constant air volume system and is balanced as a constant volume system. Balancing dampers are best located at the takeoff before the runout to the Therma-Fuser diffuser.

1. Prepare system for balancing. (Make necessary checks for diversity, fan capacities, fan rotation, minimum outside air requirements, duct leaks and static pressure controller design setting. Set outside air control damper for minimum air and return air control damper for maximum air.)
2. Open Therma-Fuser diffusers.
 - a. Open appearance panel.
 - b. Unhook tension spring from bracket adjacent to cooling thermostat. See **Fig. 2**.
 - c. If perimeter blades do not immediately drop to open position, turn the control plate slightly until they open.
 - d. Close appearance panel.

NOTE: If the Therma-Fuser diffuser is equipped with a R-Ring (Ceiling plenum relief ring) do not disconnect the spring. Use temporary balancing stops made of wood supplied with the diffuser to hold the blades open the proper distance for balancing. Thickness of the stop will depend on the size of the R-Ring used.

3. Start fans, adjust system for 100% air flow and make system checks. (Measure static pressure across filters and coils and at sensor for static pressure controller. Measure supply, return and branch duct air flow.)
4. Place a direct reading diffuser balancing hood over the face of each Therma-Fuser diffuser and adjust damper at duct takeoff to obtain maximum design air volume.
5. Return Therma-Fuser diffusers to operating condition.
 - a. Open appearance panel.
 - b. Attach tension spring to bracket (removed in step 2b).
 - c. Close appearance panel.
6. Return the remainder of the system to operating condition.

FIG. 2 REMOVE SPRING TO DROP BLADES OPEN FOR BALANCING ▼

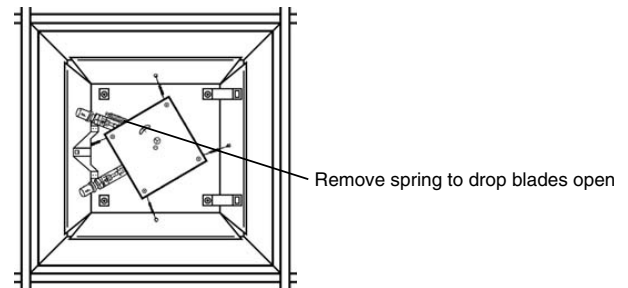

THERMA-FUSER

BALANCING

FIG. 3 OPEN FOR BALANCING ▼

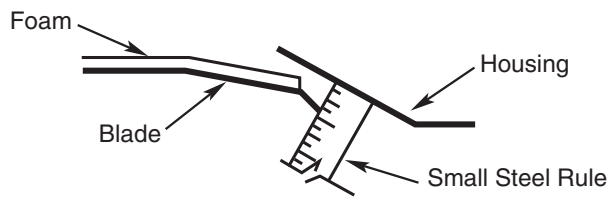

BALANCING (TF-D)

1. Measure the blade openings (See **Fig. 3**) and readjust where necessary by turning the adjusting screw in the center of each blade. Recommended initial blade openings are:

| Inlet Description | Blade Opening |
|-------------------|---------------------------------|
| 6 | $\frac{3}{8}$ " – 10mm |
| 8 | $\frac{1}{2}$ " – 13mm |
| 10 | $\frac{3}{4}$ " – 19mm |
| 12 | $1\text{-}\frac{1}{8}$ " – 29mm |

2. Adjust for proper air volume with the balancing damper at the duct takeoff. Each blade on the diffuser can also be separately adjusted. Recommended discharge velocity is 1200 fpm – 6m/sec.

THERMA-FUSER

ADJUSTING TEMPERATURE

Room temperature set points are adjusted by screwing the thermostats in or out – in for cooler or out for warmer. Determine the set point by aligning the white indicator with the °F or °C numbers on the temperature scale. (See **Fig. 4**)

FIG. 4 ROOM TEMPERATURE SET POINT ADJUSTMENT ▼

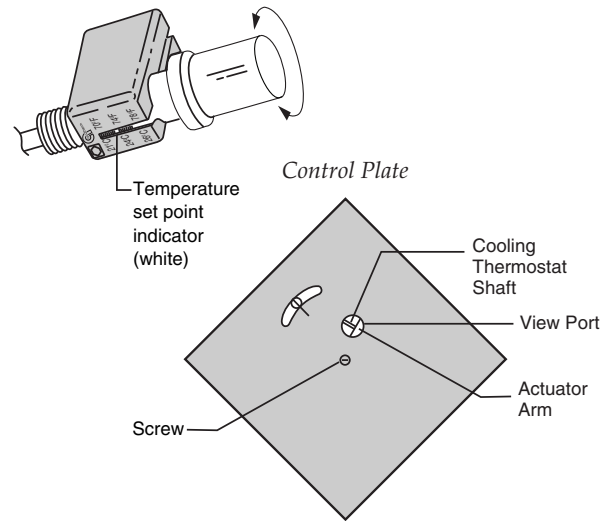

Recommended Adjustments for Various Conditions

| | ACH | SF | CFM |
|---------------------------------|----------|--------|----------------------------------------------------------------------------------------------------------------------------------------------------------------------------------------------------------------------------------------------------------------------------------------------------------------------|
| Cooling Mode STR-C STR-HC | Too Cold | open | Adjust cooling for higher room temperature set point. (Turn cooling thumbwheel out.) |
| | | closed | Therma-Fuser diffuser is correct. Check if cooling is still required, and if not, turn cooling unit off. |
| | Too Warm | open | Therma-Fuser diffuser is correct. Check for lack of air or for too warm air temperature. |
| | | closed | Adjust cooling for lower room temperature set point. (Turn cooling thumbwheel in.) |
| Heating Mode ST-HC | Too Cold | open | Therma-Fuser diffuser is correct. Check for lack of air or too low air temperature. |
| | | closed | Adjust heating for higher room temperature set point. (Turn heating thumbwheel out.) |
| | Too Warm | open | Adjust heating for lower room temperature set point. (Turn heating thumbwheel in.) |
| | | closed | Therma-Fuser diffuser is correct. Check if heating is still required, and if not, turn it off. |
| Too Noisy ST-C ST-HC | Any | Any | Reduce static pressure. Recommended static pressure is .05 to .25 wg / 10 to 62 Pa at the inlet of the diffuser. If lower noise level does not result from lower static pressure, check for and correct noise generating restrictions in the duct up stream such as large pressure drops over dampers, heaters, etc. |

The thermostats may be slightly harder to screw in or out when warm because the shaft is extended putting more pressure on the thermostat. If you are unable to turn the thermostat in this situation, cool the thermostat by holding an ice cube to the large end. The shaft will then contract and the thermostat will turn easily for adjustment.

For proper operation make sure that the extension shaft on the cooling thermostat is in the actuator arm dimple. Check by sighting through the control plate viewport. (See Fig. 4) If the shaft is not in the dimple, cool the thermostat by holding ice to the large end until the shafts retracts and move the shaft into the dimple.

THERMA-FUSER

BLOW PATTERNS (TF-C, TF-CW, AND TF-HC)

FIG. 5 FIELD INSTALLED BAFFLE ▼

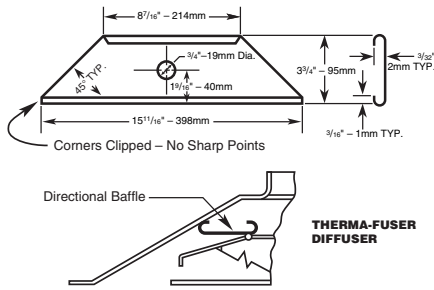
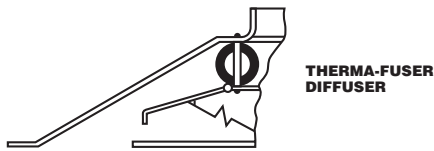

FIG. 6 FOAM DIRECTIONAL BAFFLE ▼



A major selling feature of the TF-C, TF-CW and TF-HC diffusers is the ability to easily add or remove blow patterns in the field. This is done by blocking the air off behind the blades on the appropriate sides.

DO NOT:

- Disconnect the spokes.
- Tape, screw or otherwise lock the blade closed. This unbalances the loads on the center bearings.
- Block the four venturi nozzles.

DO block air flow behind the blades or between the standoffs. (Standoffs are the supports between the housing and the diffusion plate.) Ways to do this are:

1. Factory installed directional baffles. These are strips of metal wrapped around the standoffs to block one, two or three sides. These can be removed in the field after first removing the diffusion plate assembly.
2. Field installed directional baffles. These are trapezoid pieces of metal that are laid horizontally on top of the corner supports. Dimensions are as shown in **Fig. 5**. Directional baffles can be made locally or purchased from Acutherm.
3. 1-5/8" diameter x 10" long (Armaflex) for split system refrigeration lines. Insert between the housing and the diffusion plate/blade assembly and wedge between the standoffs (See **Fig. 6**). Not supplied by Acutherm but easily available in the field.

The rule for blocking the appropriate side is: Always block the thermostat side. (See **Fig. 7** for examples.)

NOTE: Some earlier TF-C and TF-CW models have one induction slot by the thermostat instead of four venturi nozzles. The rule for blocking the appropriate side for this version is: Never block the thermostat side.

When blocking for direction, the air volume for a given static pressure is reduced from max. air volume listed in the performance guide by:

| Blow Patterns | Blade Opening |
|---------------|---------------|
| 3 way | 0.78 |
| 2 way | 0.56 |
| 1 way | 0.34 |

FIG. 7 BLOW PATTERNS ▼

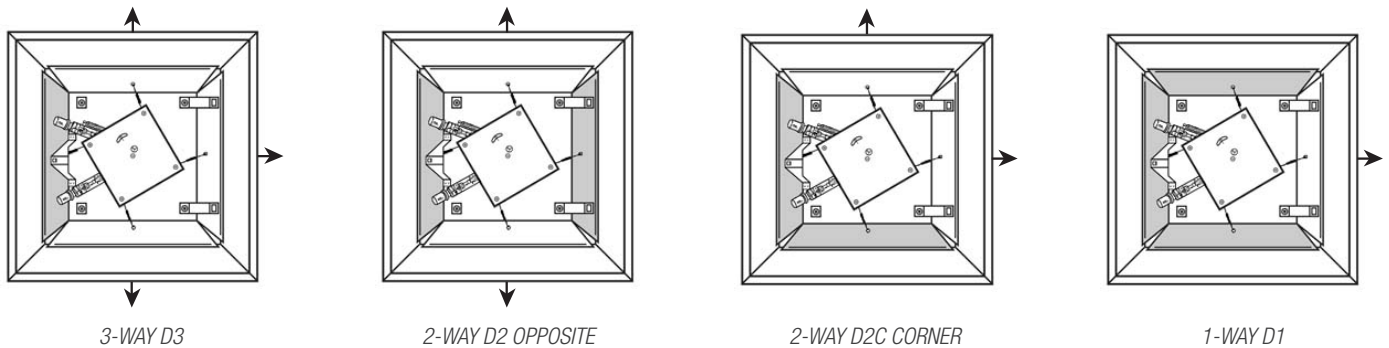

THERMA-FUSER

MAINTENANCE

The moving parts of the TF Therma-Fuser diffuser have no maintenance or lubrication requirements. We are often asked to recommend periodic maintenance procedures and a spare parts stock. Recommended maintenance is to clean the outer surfaces of the Therma-Fuser diffuser—nothing else. We do not recommend stocking any spare parts. Our customers also confirm that stocking is unnecessary.

Damper Blade Adjustment (TF-C, TF-CW, AND TF-HC)

If one of the blades does not track uniformly with the others, make a simple field adjustment to the spoke wire which connects the blade to the control plate. A pair of needle nose pliers or similar tool is all that is required. If the blade does not open as rapidly as the other blades, insert the pliers inside of the closed loop in the spoke wire and slightly expand the loop. If the blade opens more rapidly than the others, place the pliers outside of the closed loop and **slightly compress** the loop. No other adjustment is required.

THERMA-FUSER

TROUBLE SHOOTING (TF-C, TF-CW AND TF-HC)

Trouble shooting Therma-Fuser diffusers requires looking at the systems as a whole. Before examining the Therma-Fuser diffuser for failure it is worth the time to be sure the system is functioning properly and that something has not been overlooked. Before calling Acutherm, please complete the data log for all Therma-Fuser diffusers to be evaluated.

System Check

The system should be:

1. Delivering 50° - 68°F/10° - 20°C supply air when in the cooling mode.
2. Delivering 80° - 120°F/26.5° - 49°C supply air when in the heating mode (TF-CW and TF-HC).
3. Maintaining static pressure at the inlet to each Therma-Fuser diffuser between .05 and .25"wg/12 Pa and 62 Pa.
4. Maintaining continuous fan operation during occupied hours.

Therma-Fuser Diffuser Check

Once the above checks have been completed examine and record the following (Conditions may vary over time; several measurements at different times may be required):

5. Room temperature 4ft/1.2m above the floor directly under the Therma-Fuser diffuser.
6. Supply air temperature at the Therma-Fuser diffuser.
7. Static pressure at the inlet of the Therma-Fuser diffuser.
8. Blade opening from the edge of the blade, measured perpendicular to the housing.
9. Control plate position (clockwise or counter clockwise from center).
10. Cooling and heating setpoints.
11. Thermostat extension.
12. Is the Therma-Fuser diffuser located within 2ft/600mm of a vertical protrusion such as a wall or dropped beam which could disturb induction air flow?

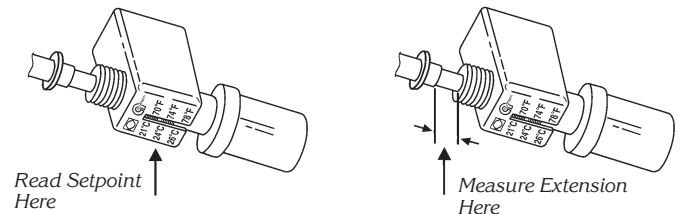
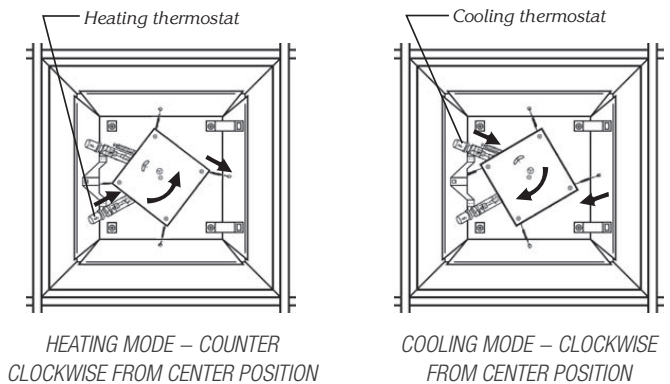
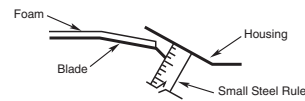

THERMA-FUSER

TROUBLE SHOOTING (TF-C, TF-CW AND TF-HC)

Data Log

| Location | Date | Time | Room /Temp | S.A. Temp | Duct S.P. | Blade Opening | Control Disk Position | Set Points | | Set Points | |
|----------|------|------|------------|-----------|-----------|---------------|-----------------------|------------|---------|------------|---------|
| | | | | | | | | Cooling | Heating | Cooling | Heating |
| | | | | | | | | | | | |
| | | | | | | | | | | | |
| | | | | | | | | | | | |
| | | | | | | | | | | | |
| | | | | | | | | | | | |
| | | | | | | | | | | | |
| | | | | | | | | | | | |
| | | | | | | | | | | | |

THERMA-FUSER

TEN YEAR WARRANTY

Acutherm warrants that its Model TF Therma-Fuser diffusers, exclusive of any options and accessories (whether factory or field installed) shall be free from defects in material or workmanship for a period of ten (10) years from the date of shipment and agrees to repair or replace, at its option, any parts that fail during said ten (10) year period due to any such defects which would not have occurred had reasonable care been taken, provided that such parts have been inspected by Acutherm and found defective and provided the diffusers have been given normal and proper usage and all parts and controls remain unaltered. Acutherm makes **NO WARRANTY OF MERCHANTABILITY OF PRODUCTS OR OF THEIR FITNESS FOR ANY PURPOSE OR ANY OTHER EXPRESS OR IMPLIED WARRANTY WHICH EXTENDES BEYOND THE LIMITED WARRANTY ABOVE. ACUTHERM'S LIABILITY FOR ANY AND ALL LOSSES AND DAMAGES RESULTING FROM DEFECTS SHALL IN NO EVENT EXCEED THE COST OF REPAIR OR REPLACEMENT OF PARTS FOUND DEFECTIVE UPON EXAMINATION BY ACUTHERM. IN NO EVENT SHALL ACUTHERM BE LIABLE FOR INCIDENTAL, INDIRECT OR CONSEQUENTIAL DAMAGES OR DAMAGES FOR INJURY TO PERSONS OR PROPERTY.** Acutherm shall not be responsible for freight to or from its plant in connection with the inspection, repair or replacement of parts under the terms of this limited warranty nor for cost of removal or installation.

This document contains the most current product information as of this printing.
For the most up-to-date product information, please go to acutherm.com

© 2022 Acutherm. All rights reserved.

