



MANUAL – INSTALLATION, BALANCING + MAINTENANCE

Mechanical Thermal VAV Diffusers

ST Series

v001 – Issue Date: 09/14/22

© 2022 Acutherm. All rights reserved.



MECHANICAL THERMAL VAV DIFFUSERS

TABLE OF CONTENTS

Installation Instructions.....	1
System Balancing.....	3
Adjusting Minimum Flow & Temperature Setpoints.....	4
Maintenance.....	6
Controlling the System.....	6
Trouble Shooting.....	7
Blow Patterns.....	9
Ten Year Warranty.....	10

MECHANICAL THERMAL VAV DIFFUSERS

INSTALLATION INSTRUCTIONS

Damaged Freight Claim Procedure

When the diffusers are received, inspect for damage which may have occurred during shipment. If damage is evident, it should be noted on the carrier's freight bill. A written request for inspection by the carrier's agent should be made at once.

Storage

Cartons should always be stacked on end with the arrows on the cartons pointing up. Do not stack cartons flat on the sides. Excessive weight may cause damage to the diffusers. Do not store for prolonged times at temperatures exceeding 130°F/56°C.

Identification

Diffusers are factory shipped one per carton. The model designation is on the diffuser and on the carton.

Installation Precautions

When installing diffusers, make sure construction debris does not enter the diffuser or duct system.

Because the models ST-C and ST-HC control room temperature by sensing the room air induced up the center of the room, care should be taken not to disturb room air induction and entrainment. For example, location next to walls or dropped lights results in the reflection of primary air back at the Therma-Fuser diffuser and should be avoided. A three-way blow Therma-Fuser diffuser should be used in this instance if either the light or the Therma-Fuser diffuser cannot be relocated.

Installation Instructions

1. Inspect the carton for damage before opening. Notify carrier if external damage exists. Submit all claims for shipping damage to the carrier.
2. Move diffusers (in cartons) to installation area. Note unit identification.
3. Remove cardboard box and cardboard insert. Discard packing material.
4. If other than 4 way blow pattern is factory installed, note the "AIRFLOW" markings on the top of the diffuser and locate those sides in the proper direction.
5. Install in ceiling grid. Install T-bar support wire close to each corner of diffuser. Make sure that only wire suspended T-bars are used to support diffuser weight. (Adaptor frames are available for other than lay in ceilings.)
6. Connect and secure the supply duct to the collar. Flexible duct should NOT be formed in a centerline radius of less than 1½ times the duct diameter.
7. Do NOT reset the temperature set point on the ST-C and ST-HC models until the space is occupied. The set point is factory preset for average conditions (74°F/23°C).
8. Balance the system. See **System Balancing**.
9. After the air conditioning system is started and **after the space is occupied**, where necessary adjust the temperature set point on ST-C and ST-HC models to suit the occupant. See **Adjusting Temperature**.

Operating Instructions

Operating instructions for models ST-C and ST-HC are located on the back of the appearance panel. See **Fig. 2**.

FIG. 1 DIMENSIONS ▼

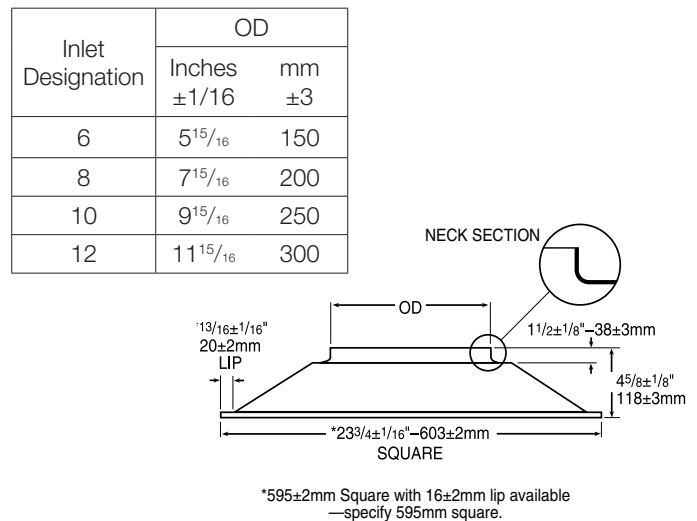

MECHANICAL THERMAL VAV DIFFUSERS

INSTALLATION INSTRUCTIONS

Opening the Appearance Panel

The appearance panel is attached with two latch clips on one side and hinges on the opposite side.

To open the appearance panel (on a Therma-Fuser diffuser installed in the ceiling):

1. Locate the side of the Therma-Fuser diffuser with the thermostat. Using two hands, one on each side of the channel, place your fingers above the appearance panel and firmly pull down to disengage the clips. The appearance panel will rotate and hang down vertically on the hinges. See **Fig. 2**.

To remove the appearance panel:

1. Rotate the panel upward.
2. Latch the panel by pushing the clips into the small square holes in the channel.

To close the appearance panel:

1. Open appearance panel as described above.
2. Rotate the appearance panel away from the latch clip bracket to force the hinge hooks open on the panel.
3. Slightly lift the panel to remove from the hinges.

To close the appearance panel:

1. Open appearance panel as described above.
2. Rotate the appearance panel away from the latch clip bracket to force the hinge hooks open on the panel.
3. Slightly lift the panel to remove from the hinges.

To reattach the appearance panel:

1. Hang the appearance panel on the hinges.
2. Press the hinge hooks against the panel to close around the hinge brackets.
3. Close panel as describe above.

FIG. 2 OPEN APPEARANCE PANEL ▼

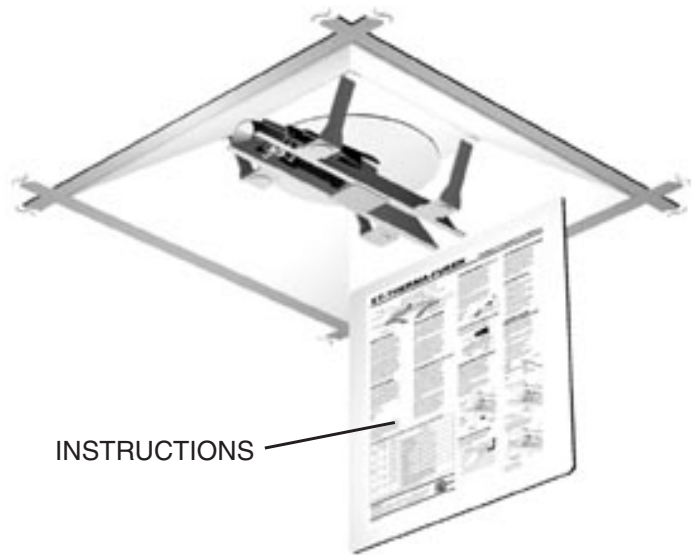

MECHANICAL THERMAL VAV DIFFUSERS

SYSTEM BALANCING

VAV systems are balanced for design air volume at maximum air flow and systems using Therma-Fuser VAV diffusers are no exception. When all the Therma-Fuser diffusers are set for maximum air flow by fully opening them, the system is really a constant air volume system and is balanced as a constant volume system. Balancing dampers are best located at the takeoff before the runout to the Therma-Fuser diffuser.

1. Prepare system for balancing. (Make necessary checks for diversity, fan capacities, fan rotation, minimum outside air requirements, duct leaks and static pressure controller design setting. Set outside air control damper for minimum air and return air control damper for maximum air.)
 2. Open Therma-Fuser diffusers. ST-C and ST-HC.
 - a. Locate the side of the ST diffuser with the thermostat and the balancing lever.
 - b. Push the balancing lever to the right and up. See **Fig. 3**.
 3. Start fans, adjust system for 100% air flow and make system checks. (Measure static pressure across filters and coils and at sensor for static pressure controller.)
 4. Measure air flow from each Therma-Fuser diffuser and adjust the damper at the duct takeoff to obtain maximum design air flow. Air flow measurement may be with a direct reading diffuser balancing hood or air velocity meter. **In either case, measurements are made with all appearance panels in place.** This is because the appearance panel affects pressure drop through the diffuser. When a velocity meter is used to measure the discharge velocity, the velocity is measured at the top edge of the housing. See **Fig. 4**.
- Ak factors when the Therma-Fuser diffuser is fully open are as follows:
5. Return Therma-Fuser diffusers to operating condition by pushing the balancing lever down until it latches.

FIG. 3 OPEN FOR BALANCING ▼

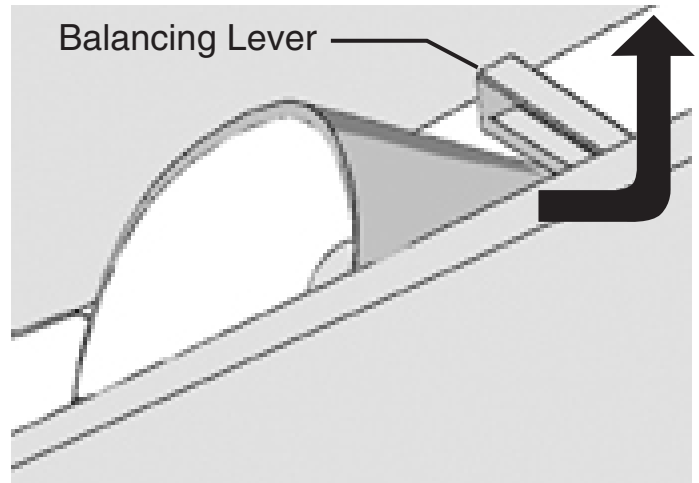

MECHANICAL THERMAL VAV DIFFUSERS

ADJUSTING MINIMUM FLOW & TEMPERATURE SETPOINTS

Adjusting Minimum Flow

Turn dial until desired minimum flow on the scale intersects with the lower metal piece. See **Fig. 5**.

Adjusting Temperature Setpoints

The ST Thermo-Fuser diffuser is factory set at 74°F/23°C. Because heat loads in various rooms differ and individual occupants prefer different temperatures, it is recommended that the thermostat not be adjusted until after a few days of operation.

Room temperature setpoints for heating and cooling are separately adjusted by turning the heating and cooling thumbwheels. Align the outside of each thumbwheel with its respective temperature scale. See Fig. 6. Each setpoint can be anywhere between 70° and 78°F/21° and 25°C. See **Fig. 6**.

Inlet Description	A _k Factor
6	0.13 ft ²
8	0.18 ft ²
10	0.24 ft ²
12	0.33 ft ²

Both are factory set at 74°F/23°C. (The model ST-C has only one thumbwheel).

If the cooling thumbwheel is tight when the room is cool, continue to turn the thumbwheel and pull the changeover close rod outward to relieve the tightness. See **Fig. 6**.

FIG. 4 MEASURING VELOCITY ▼

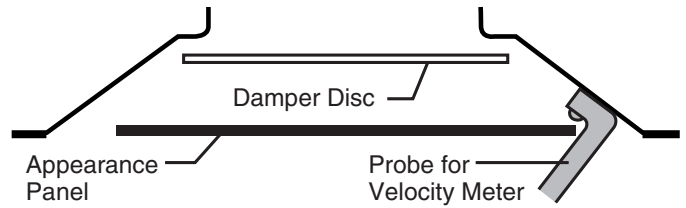

FIG. 5 ADJUSTING MINIMUM FLOW ▼

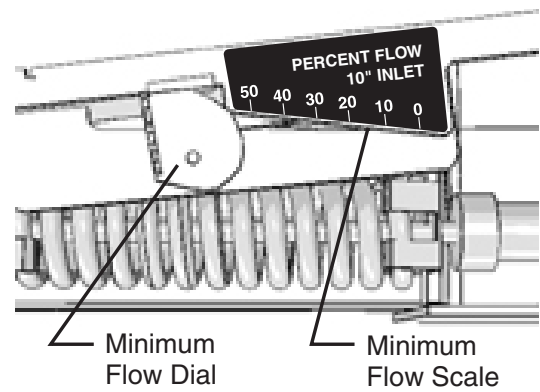
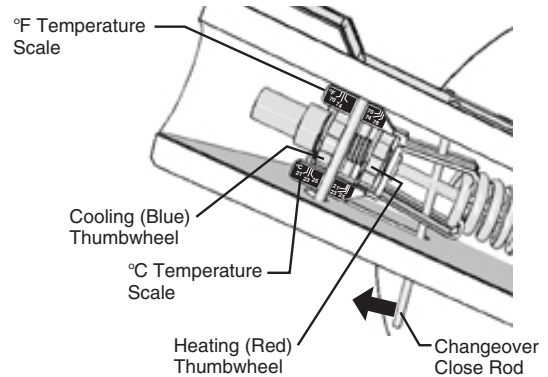

FIG. 6 ADJUSTING TEMPERATURE ▼



MECHANICAL THERMAL VAV DIFFUSERS

ADJUSTING MINIMUM FLOW & TEMPERATURE SETPOINTS

Recommended Adjustments for Various Conditions

	ACH	SF	CFM
Cooling Mode ST-C ST-HC	Too Cold	open	Adjust cooling for higher room temperature set point. (Turn cooling thumbwheel out.)
		closed	Therma-Fuser diffuser is correct. Check if cooling is still required, and if not, turn cooling unit off.
	Too Warm	open	Therma-Fuser diffuser is correct. Check for lack of air or for too warm air temperature.
		closed	Adjust cooling for lower room temperature set point. (Turn cooling thumbwheel in.)
Heating Mode ST-HC	Too Cold	open	Therma-Fuser diffuser is correct. Check for lack of air or too low air temperature.
		closed	Adjust heating for higher room temperature set point. (Turn heating thumbwheel out.)
	Too Warm	open	Adjust heating for lower room temperature set point. (Turn heating thumbwheel in.)
		closed	Therma-Fuser diffuser is correct. Check if heating is still required, and if not, turn it off.
Too Noisy ST-C ST-HC	Any	Any	Reduce static pressure. Recommended static pressure is .05 to .25 wg / 10 to 62 Pa at the inlet of the diffuser. If lower noise level does not result from lower static pressure, check for and correct noise generating restrictions in the duct up stream such as large pressure drops over dampers, heaters, etc.

MECHANICAL THERMAL VAV DIFFUSERS

MAINTENANCE & CONTROLLING THE SYSTEM

Maintenance

The moving parts of the ST Therma-Fuser diffuser have no maintenance or lubrication requirements. We are often asked to recommend periodic maintenance procedures and a spare parts stock. Recommended maintenance is to clean the outer surfaces of the Therma-Fuser diffuser—nothing else. We do not recommend stocking any spare parts. Our customers also confirm that stocking is unnecessary.

Controlling the System

References:

- System Design, p 4, ST brochure, Form 10.1.
- Chapters 2.2, 3.1 and 3.2, pp 6, 7 and 8, Designing Modular VAV Systems, Form 5.2.
- Air Handling and Fan Coil Units Subzoned with Therma-Fuser VAV modules, Form 6.7.
- DX Equipment Zoned with Therma-Fuser VAV Modules, Form 6.5.

Supply Air Temperature

The sources of cooling and heating are controlled from supply air temperature. As with all VAV systems, the goals are to achieve a constant supply air temperature (may be reset to another **constant** supply air temperature) and to limit the supply air temperature. Limits for supply air temperature should be between 50°F/10°C and 68°F/20°C when cooling and between 80°F/26.5°C and 120°F/49°C when heating. The heating temperature limit should be as low as possible. These objectives are best achieved by modulating chilled water valves, hot water valves and other variable equipment from supply air temperature. On/off equipment such as DX compressors and electric heat are cycled from supply air temperature. Use a discharge air sensor for the supply air temperature signal.

Mode change between heating, recirculation and cooling is controlled from room temperature. Signals from one or more room temperature sensors may be used for mode change. When using more than one sensor, either a “majority rules” or a “cooling dominant” approach is recommended.

Static Air Pressure

As with all VAV systems, the fan must run continuously during occupied times. Goals of static pressure control are to provide enough static pressure to obtain the required air volume especially at the diffuser farthest from the fan, to avoid diffuser noise by limiting static pressure at both full flow and turndown and to provide pressure independence or consistent operation as the system flow changes.

These objectives can be achieved with the usual methods of automatic static pressure control: bypass dampers, discharge dampers, zone dampers, and fan control (variable speed drives, inlet dampers, etc.). Locate the static pressure sensor as far down the duct as possible—at least 2/3 down the duct from the first takeoff.

MECHANICAL THERMAL VAV DIFFUSERS

TROUBLE SHOOTING

Trouble shooting Therma-Fuser diffusers requires looking at the system as a whole. Before examining the Therma-Fuser diffuser for failure, it is worth the time to be sure the system is functioning properly and that something has not been overlooked. Before calling Acutherm, please complete the data log for all Therma-Fuser diffusers to be evaluated.

System Check

The system should be:

1. Delivering 50° - 68°F / 10° - 20°C supply air when in the cooling mode.
2. Delivering 80° - 120°F / 26.5° - 49°C supply air when in the heating mode.
3. Maintaining static pressure at the inlet to each Therma-Fuser diffuser between .05 and .25"wg / 12 Pa and 62 Pa.
4. Maintaining continuous fan operation during occupied hours.

Therma-Fuser Diffuser Check List

Once the above checks have been completed, examine and record the following (Conditions may vary over time; several measurements at different times may be required):

1. Room temperature 4ft / 1.2m above the floor directly under the Therma-Fuser diffuser.
2. Supply air temperature at the inlet of the Therma-Fuser diffuser.
3. Static pressure at the inlet of the Therma-Fuser diffuser.
4. Damper disc opening from the edge of the disc, measured vertically to the housing. See **Fig. 7**.
5. Changeover close rod position—inward or outward. See **Fig. 8**.
6. Cooling and heating setpoints. See **Fig. 6**.
7. Room thermostat position measured
8. Min. flow stop setting—percent flow. See **Fig. 5**.
9. Balancing lever position—open or closed. See **Fig. 3**.
10. Is the Therma-Fuser diffuser located within 2ft / 600mm of a vertical protrusion such as a wall or dropped beam which could disturb induction air flow?

FIG. 7 MEASURE DISC OPENING ▼

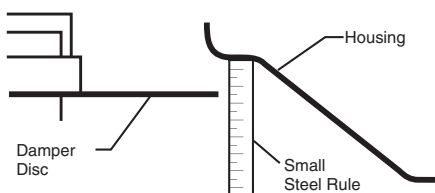

FIG. 8 CHANGEOVER ROD ▼

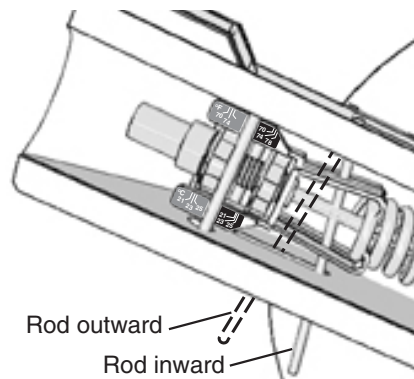
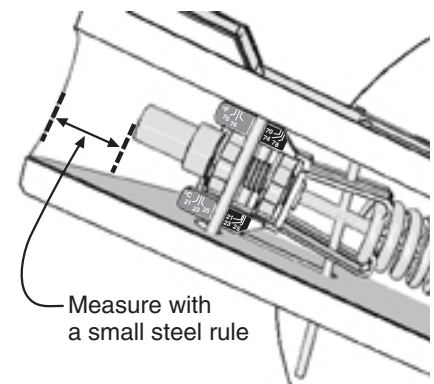

FIG. 9 MEASURE THERMOSTAT POSITION ▼



MECHANICAL THERMAL VAV DIFFUSERS

TROUBLE SHOOTING

Trouble Shooting Data Log

Location	Date	Time	Room /Temp	S.A. Temp	Duct S.P.	Disc Opening	Changeover Close Rod Position

Set Points		Room Thermostat Position	Min. Flow Stop Setting	Balance Lever Position	Location By Wall Etc?
Cooling	Heating				

MECHANICAL THERMAL VAV DIFFUSERS

BLOW PATTERNS

FIG. 10 DIRECTIONAL BAFFLE LOCATION ▼



FIG. 11. CORRECT SIDES TO BLOCK ▼

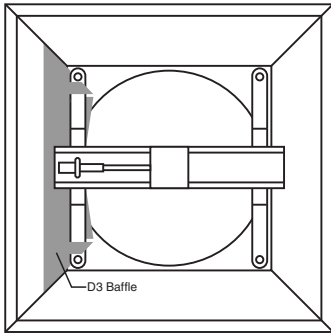

THREE WAY BLOW — D3

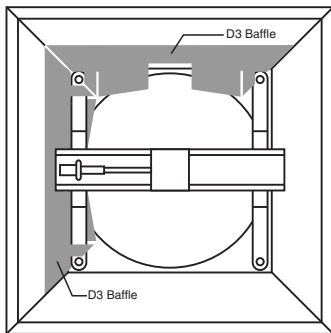

TWO WAY BLOW, CORNER — D2C

NOTE: A D2C requires two D3 baffles.

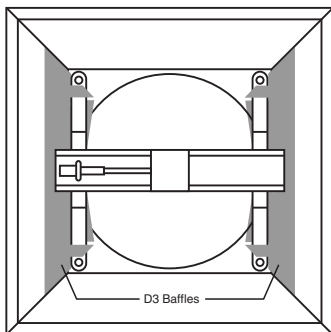

TWO WAY BLOW, OPPOSITE — D2

Blow Patterns are added by blocking off the air on the appropriate sides with Acutherm directional baffles. To increase capacity and throw from the unblocked sides, the baffles fold around the diffusion disc. See **Fig. 10**.

The rule for blocking the appropriate side is:

ALWAYS INSTALL DIRECTIONAL BAFFLES ON THE THERMAL ELEMENT SIDE OF THE THERMA-FUSER DIFFUSER. See **Fig. 11**.

When blocking for direction with the Acutherm directional baffles shown above, the air volume for a given static pressure is reduced from max. flow listed in the performance guide by:

Inlet Designation	Reduction		
	3 Way	2 Way Corner	2 Way Opposite
6	0.99	0.99	1.00
8	0.97	0.86	0.87
10	0.88	0.75	0.72
12	0.85	0.65	0.77

Note that in some instances, even though the pattern is satisfactory for most applications, the block off is not complete. As a result, a three-way ST model is ineffective for inducing room air up a wall or window. **DO NOT USE A 3-WAY ST MODEL TO INDUCE ROOM AIR UP A WALL OR WINDOW.**

Field Installing Blow Patterns

Acutherm directional baffles are best installed one side at a time. To do this:

1. Open Therma-Fuser diffuser. ST-C and ST-HC.
 - a. Open appearance panel. See Opening the Appearance Panel, Pg. 2.
 - b. Push the balancing lever to the right and up. See Fig. 3.
2. Remove the two corner screws that attach the channel assembly on the side to be blocked off. Make sure you are blocking off the correct side. The side with the thermostat should always be blocked first.
3. Slide the Acutherm directional baffle between the channel bracket and the housing. The slots in the baffles must be away from the housing and toward the bottom of the diffuser.
4. Replace and tighten the two corner screws.
5. For two-way blow patterns, repeat the above steps for the second side to be blocked off.

MECHANICAL THERMAL VAV DIFFUSERS

TEN YEAR WARRANTY

Acutherm warrants that its Model ST Therma-Fuser diffusers, exclusive of any options and accessories (whether factory or field installed) shall be free from defects in material or workmanship for a period of ten (10) years from the date of shipment and agrees to repair or replace, at its option, any parts that fail during said ten (10) year period due to any such defects which would not have occurred had reasonable care been taken, provided that such parts have been inspected by Acutherm and found defective and provided the diffusers have been given normal and proper usage and all parts and controls remain unaltered. Acutherm makes **NO WARRANTY OF MERCHANTABILITY OF PRODUCTS OR OF THEIR FITNESS FOR ANY PURPOSE OR ANY OTHER EXPRESS OR IMPLIED WARRANTY WHICH EXTENDS BEYOND THE LIMITED WARRANTY ABOVE. ACUTHERM'S LIABILITY FOR ANY AND ALL LOSSES AND DAMAGES RESULTING FROM DEFECTS SHALL IN NO EVENT EXCEED THE COST OF REPAIR OR REPLACEMENT OF PARTS FOUND DEFECTIVE UPON EXAMINATION BY ACUTHERM. IN NO EVENT SHALL ACUTHERM BE LIABLE FOR INCIDENTAL, INDIRECT OR CONSEQUENTIAL DAMAGES OR DAMAGES FOR INJURY TO PERSONS OR PROPERTY.** Acutherm shall not be responsible for freight to or from its plant in connection with the inspection, repair or replacement of parts under the terms of this limited warranty nor for cost or installation

This document contains the most current product information as of this printing.
For the most up-to-date product information, please go to acutherm.com

© 2022 Acutherm. All rights reserved.

