

EF-B BACnet INTEROPERABLE VAV DIFFUSER

DIRECTIONAL BLOW PATTERNS

Models: EF-B BACnet Interoperable VAV Diffuser

Because the Model EF-B BACnet Interoperable VAV diffuser controls room temperature by sensing the room air induced up the center of the room, care should be taken not to locate the diffuser too close to an obstruction (i.e. next to walls or dropped lights) as the reflection of primary air back at the Therma-Fuser diffuser will cause an incorrect measurement of room temperature. Directional blow patterns (baffles) should be used if the diffuser needs to be located closer than 24in to an obstruction.

Directional Blow Patterns

Directional blow patterns are used to block the air flow from one or more sides of the diffuser when the diffuser needs to be located near an obstruction. Blow patterns can be factory installed or baffles may be installed in the field.

Field Installation

Do not disconnect the spokes, tape, screw or otherwise lock the blade closed (this unbalances the loads on the center bearings) or block the four venturi nozzles.

Field installed directional baffles are trapezoid pieces of metal that are laid horizontally on top of the corner supports (see Fig. 1 and 2).

The rules for blocking the appropriate side are:

1. Always block the thermostat side first (see Fig. 3). Rotate the diffuser so that the thermostat side is located next to the obstruction.
2. For each baffle installed, the flow sensor for that side must be disabled. Disable the flow sensor by disconnecting the appropriate wire for the side blocked (see Fig. 3 and 4).

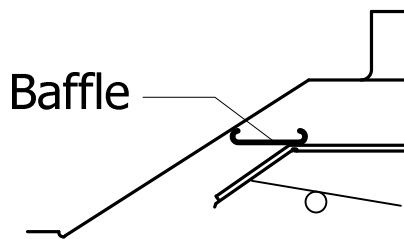

Fig. 1 Baffle Installed

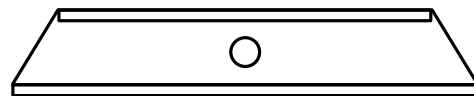

Fig. 2 Baffle

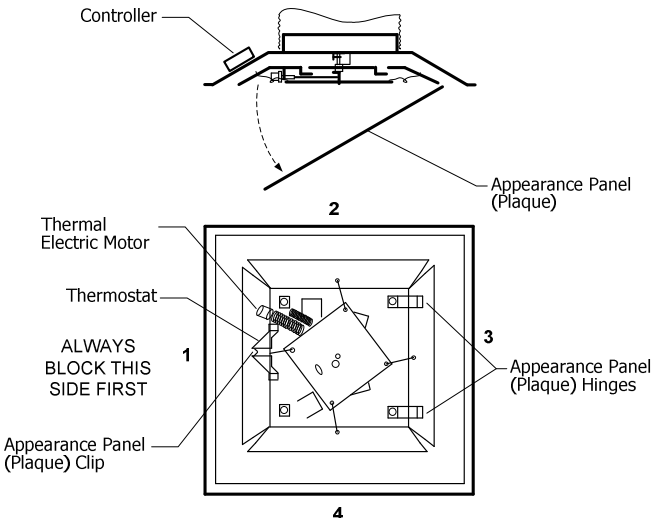

Fig. 3 Always Block the Thermostat Side First

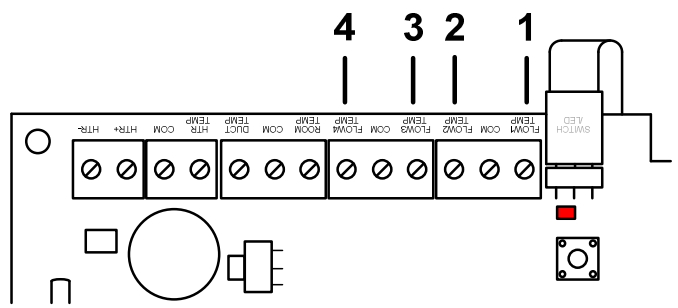
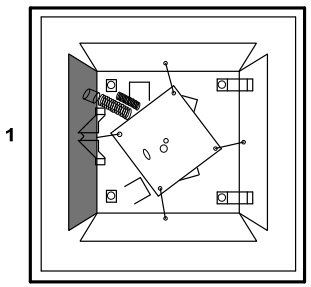
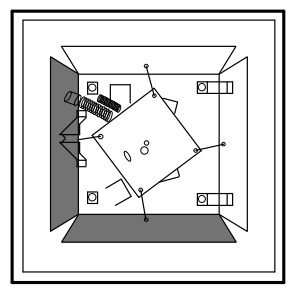

Fig. 4 Flow Sensor Wiring of Control Board – Disconnect sensor corresponding to side(s) blocked.

Fig. 5 Options for Directional Blow



3-Way Blow
 Block thermostat side 1.
 Disconnect sensor 1.



2-Way Corner Right
 Block thermostat side 1
 and side 4. Disconnect
 sensors 1 and 4.

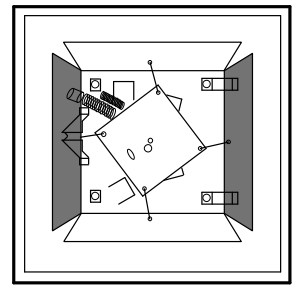

2-Way Opposite
 Block thermostat side 1
 and side 3. Disconnect
 sensors 1 and 3.

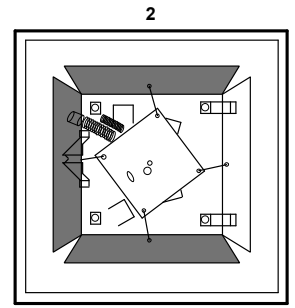

1-Way Blow
 Block thermostat side 1
 and sides 2 and 4.
 Disconnect sensors 1, 2
 and 4.

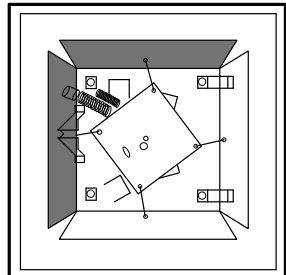

2-Way Corner Left
 Block thermostat side 1
 and side 2. Disconnect
 sensors 1 and 2.