

THE TF-HC STAND ALONE THERMA-FUSER™

THERMALLY POWERED VAV DIFFUSER



The only Thermally Powered Terminal Offering both VAV Heating and VAV Cooling. Handles Duct Temperatures to 120°F/49°C when Heating and Cools without Dumping.

Two Room Thermostats

- One for VAV Heating, another for VAV Cooling
- Separately Adjustable 70°-78°F/21°-26°C
- Concealed, Out of Casual Reach
- Easily Accessed

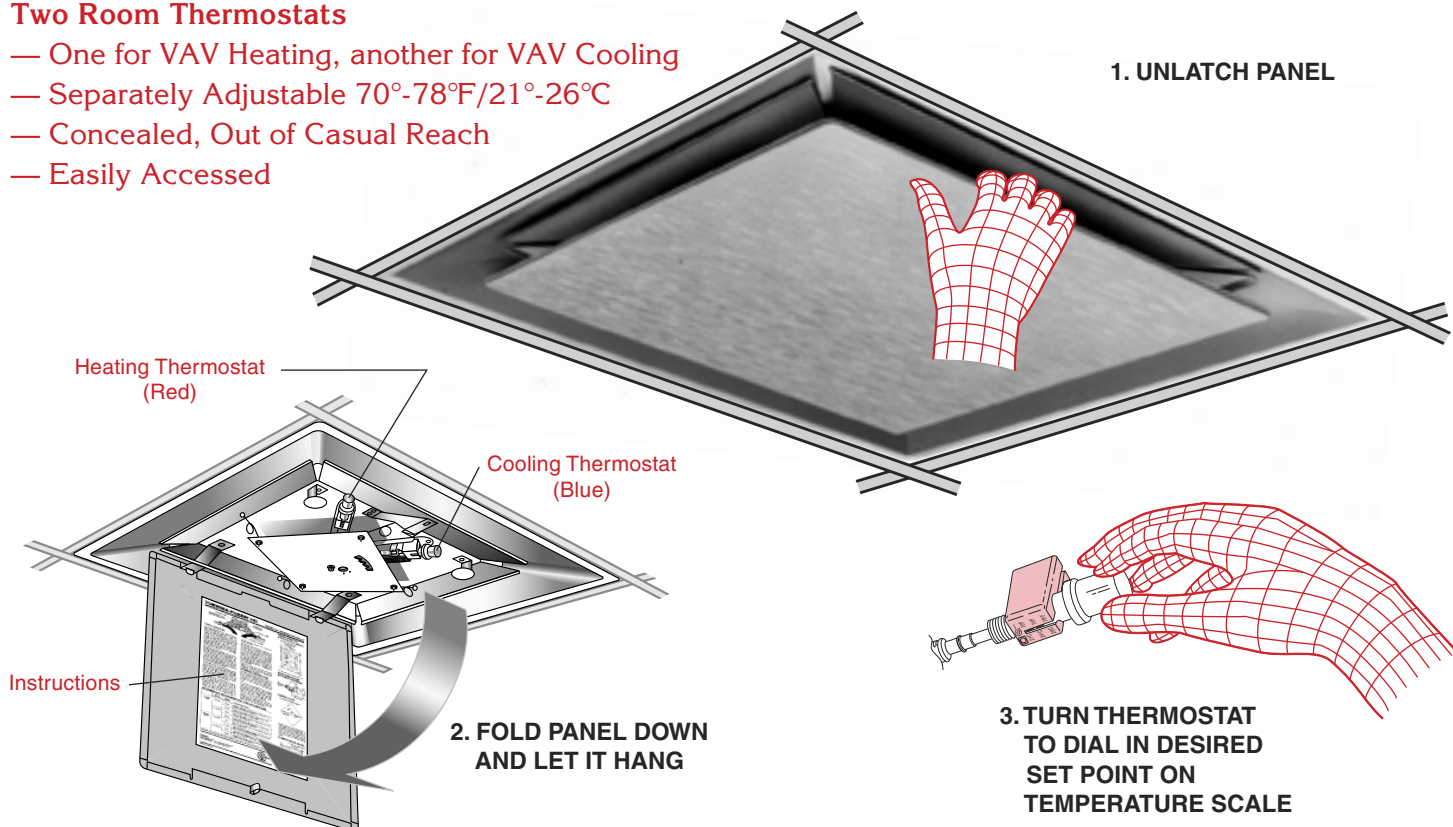

INDIVIDUAL COMFORT SELECTION AND CONTROL

Every Therma-Fuser™ diffuser is a VAV zone of temperature control providing pleasing comfort in both heating and cooling. Built in thermostats sense average room air temperature from a sample of air induced into the unit. It controls air flow to precisely match the comfort requirements of the room or portion of the room served. Occupants breathe easier knowing that their personal temperature choice will not be changed by someone else.

EASY LOW COST INSTALLATION

No special skills or equipment are required to install Therma-Fuser VAV diffuser—just connect the supply air duct. Expensive electrical or pneumatic connections and complicated controls are eliminated. Delicate “system powered” devices which need larger more expensive fans are not involved. Maintenance and recalibration are eliminated too, even over the long term, due to the dependability of the durable wax motor.

*ADPI (Air Diffusion Performance Index) is defined in the ASHRAE Fundamentals Handbook.

ONLY THERMA-FUSER VAV DIFFUSER OFFERS THESE BENEFITS

- Superior air distribution—longer throws, no dumping more entrainment, even temperature distribution, higher ADPI* and better ventilation effectiveness.
- Lowest cost per zone of control.
- Lowest energy VAV terminal—green VAV.
- Low to no maintenance—10 year warranty.
- Easily adapts to office changes.
- Only thermally powered terminal offering both VAV heating and VAV cooling.

TF-HC THERMA-FUSER™ DIFFUSER—

The only thermally powered terminal offering both VAV heating and VAV cooling. No uncomfortable over heating during warm-up cycles plus temperature control for both VAV heating and cooling.

COANDA EFFECT

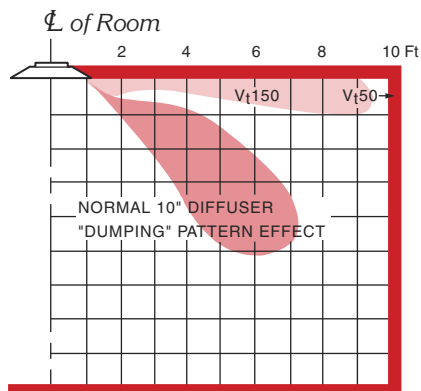

10" neck at 25% of maximum cfm with 55°F supply temperature

ENTRAINMENT EFFECT

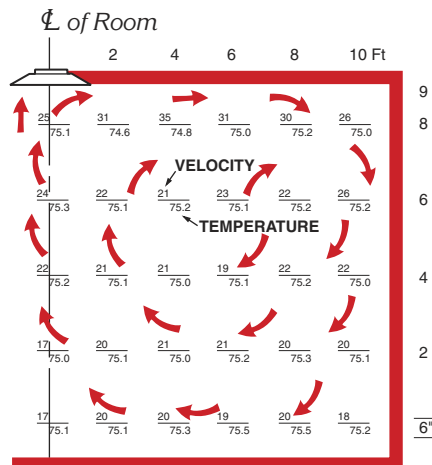

Based on 0.2 cfm/sq. ft. with 55°F supply air temperature.

NOTES

- Both fixed and adjustable **minimum flow stops** are available.
- For **blow patterns** reduce maximum four way air volume from the performance guide by:

Blow Pattern	Reduction
3 way (D3)	.78
2 way (D2, D2C)	.56
1 way (D1)	.34
- For **R-Rings**, blow patterns are not available. 4-way blow only.

INDIVIDUAL TEMPERATURE CONTROL

Each Therma-Fuser diffuser is a VAV zone. The thermostats, actuator and damper are built into the diffuser. Temperature set points for both heating and cooling are separately adjusted between 70°F/21°C and 78°F/26°C. It easily zones open offices.

SUPERIOR AIR DISTRIBUTION

Unlike the fixed opening diffusers used with VAV boxes, Therma-Fuser diffusers vary the discharge opening as they vary air volume. The result is a constant discharge velocity with comfort benefits of higher throws, no dumping, better room air movement and uniform temperature distribution—especially when turned down.

BETTER SENSES AVERAGE ROOM TEMPERATURE

Unlike wall thermostats, Therma-Fuser thermostats are never in the wrong location. They maintain average temperature within 1½°F/0.9°C of set point by sensing secondary space air at all times. And secondary air is the return air of the space—the best place to sense the average room temperature.

LOWEST COST PER ZONE OF CONTROL

A single trade can install Therma-Fuser VAV diffusers because it is self contained. When comparing total installed cost—including labor—systems with Therma-Fuser VAV are clearly the lowest cost of any VAV alternative.

LOWEST ENERGY VAV TERMINAL

Therma-Fuser diffusers have the lowest pressure drop of any VAV terminal which allows low pressure systems and low energy fan motors. Fan energy is further reduced by a variable speed drive when the system turns down. It saves refrigeration and heating energy because no portion of the building is overcooled or overheated. No energy is required to operate the Therma-Fuser controls.

PERFORMANCE GUIDE

Nominal Inlet Diameter	Inlet Static Pressure In. wg	Maximum Flow cfm	Maximum Flow		25% Maximum Flow	
			Throw* - Feet @v _t =50/100/150FPM	NC	Throw* - Feet @v _t =50/100/150FPM	NC
6"	.05	100	6/4/3	<15	3/2/1	<15
	.10	140	8/5/4	20	4/3/2	17
	.15	175	9/6/5	26	5/4/3	21
	.20	200	9/7/6	31	6/5/3	24
	.25	220	10/8/7	34	7/6/4	27
8"	.05	160	8/6/4	<15	5/3/2	<15
	.10	225	10/7/5	20	6/4/3	16
	.15	275	11/8/6	25	7/5/3	21
	.20	320	12/9/7	30	8/6/4	25
	.25	355	13/10/8	34	9/6/4	28
10"	.05	260	9/7/5	15	7/6/4	<15
	.10	370	11/8/6	23	9/7/5	18
	.15	450	13/10/8	27	10/8/6	22
	.20	520	14/11/9	31	11/9/7	26
	.25	580	15/12/10	34	12/10/7	29
12"	.05	350	11/8/6	15	7/6/4	<15
	.10	470	13/10/8	23	9/7/5	19
	.15	560	15/12/10	27	10/8/6	23
	.20	640	16/13/11	31	12/10/8	27
	.25	720	17/14/12	34	14/11/9	30

• Denotes nominal rating

NC based on L_w(10⁻¹² watts reference)–10db

* Throw data is for air 20°F/11°C lower than room temperature. Throws for ISO thermal air are 40% to 50% greater.

Tested in accordance with ANSI/ASHRAE 70-1991, ANSI S12.31, ARI 890-94, ISO 5219 and ISO 3741. Metric performance guide available on request.

USE THERMA-FUSER™ DIFFUSERS TO:

- **Design new building systems for individual temperature control at low initial cost.**
- **Upgrade existing building systems for individual temperature control without replacing duct work.**
- **Solve specific problems where two or more people are uncomfortable or can not agree on the thermostat setting.**



LOW TO NO MAINTENANCE

Customers using Therma-Fuser diffusers for as long as 20 years testify that no maintenance at all has been required. What VAV box or control offers similar results? Or the Acutherm 10 year warranty?

EASILY ADAPTS TO OFFICE LAYOUT CHANGES

No Therma-Fuser zone is split when office walls are put up or moved, a common problem with VAV boxes.

AESTHETIC APPEARANCE, "ARCHITECTURAL LOOK"

The clean lines of the "architectural square panel" harmonize with the ceiling resulting in a virtually unbroken ceiling plane.

TF-HC THERMA-FUSER DIFFUSER APPEARANCE PANEL REMOVED

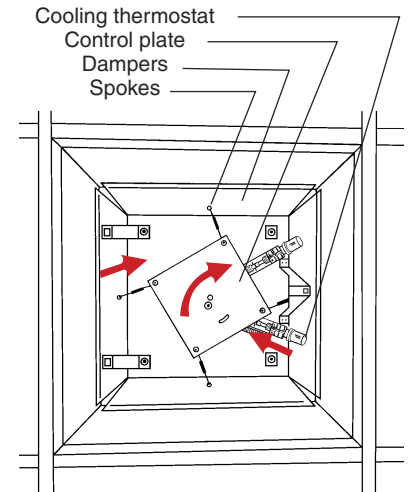

In cooling mode, as room warms dampers open

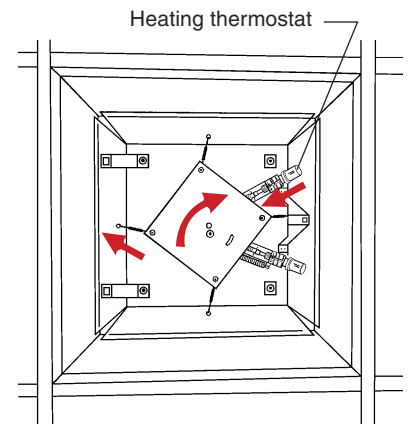

In heating mode, as room warms dampers close

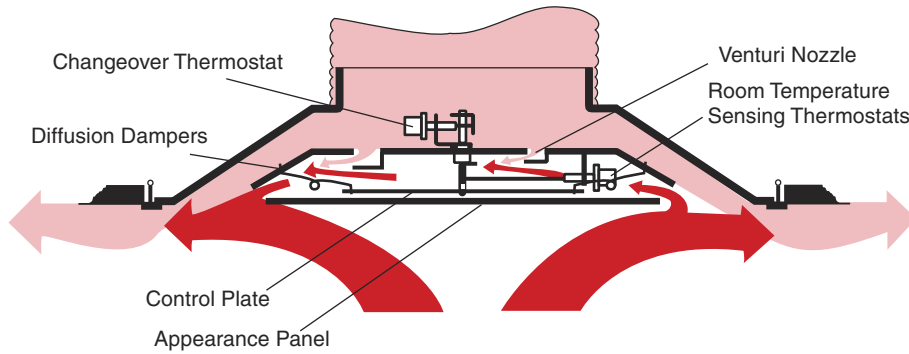

HOW IT WORKS

The model TF-HC Therma-Fuser diffuser is a 24" x 24" ceiling diffuser with built-in temperature controls. The TF-HC has four dampers that open and close to meter air flow (warm or cold) into the room in response to room temperature. The dampers are mechanically actuated by thermal element thermostats.

Each thermostat is a small brass cylinder containing a petroleum-based wax. The wax expands when heated, driving a piston out. A spring retracts the piston when the wax is cooled and contracts. The movement of the piston positions the dampers in a proportional manner.

Average room temperature is monitored by inducing a sample of air from the room across the thermostats. Because this sample is drawn directly from the air circulation pattern in the room, just before it mixes with supply air flowing into the room, it better represents average room temperature than does a wall mounted thermostat. A properly applied TF-HC will hold the room within 1.5°F of the temperature selected.

Room temperature may be set between 70°F/21°C and 78°F/25.5°C by turning the thermostat. Separate room thermostats for heating and cooling may be set at the same or different temperatures. The thermostats are concealed and out of casual reach but are easily accessible by folding down a hinged panel.

Changeover between heating and cooling modes is determined by supply air temperature. A third thermostat located in the inlet of the Therma-Fuser diffuser senses supply air temperature as it enters from the duct. Changeover from cooling to heating begins at supply air temperature of 76°F/24.5°C and completes around 80°F/26.5°C. Changeover is achieved by disengaging the cooling thermostat and engaging the heating thermostat. Changeover back to cooling is completed when the supply air temperature reaches 68°F/20°C.

When supply air is warm, the Therma-Fuser diffuser operates in the heating mode—the dampers open on a drop in room temperature. When the supply air is cold, it operates in the cooling mode—the dampers open on a rise in room temperature.

ADJUSTING TEMPERATURE

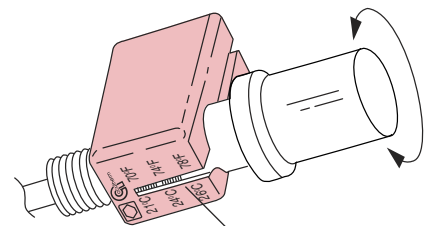

Temperature set point indicator (white)

Room temperature set points for heating and cooling are separately adjusted by screwing the heating (red scale) or cooling (blue scale) thermostats in or out—in for cooler and out for warmer. Determine the set point by aligning the white indicator with the °F or °C numbers on the temperature scale.

THERMA-FUSER™ THERMALLY POWERED VAV DIFFUSER

SYSTEM DESIGN

The best control for heating/cooling units supplying air to VAV terminals is a discharge thermostat which maintains a constant supply air temperature. With DX equipment these are a high and low limit. For hybrid systems (part VAV and part constant volume) control the heating/cooling supply unit with a thermostat in one of the rooms with a constant volume diffuser, preferably the space with the greatest load. For both VAV or hybrid systems, the fan should run continuously.

The constant discharge velocity of Therma-Fuser diffusers at varying air flow provides good room circulation which reduces stratification. Keeping heating supply air temperatures as low as possible will further reduce room air stratification to a negligible level. Static pressure at the inlet of the Therma-Fuser diffuser should be between .05"wg./12Pa and .25"wg./62Pa, at full and partial air flows. Static pressure below .05"wg./12Pa will result in low air flow and less induction. Above .25"wg./62Pa, Therma-Fuser diffusers operate well but excessive noise may result. Use minimum flow stops where tight shut off is not needed.

If the system turns down more than 30%, static pressure should be controlled. Included in the options for static pressure control are bypass, fan control and discharge dampers. Zone dampers are recommended where several zones share a higher pressure duct or riser.

When designing ducts, if Therma-Fuser diffusers are to deliver nominal volume at inlet SP of .15"wg./37Pa and if a maximum SP of .25"wg./62Pa is to be held for quiet operation, size the duct for a maximum pressure drop of .1"wg./25Pa between the first and last takeoff.

Manual balancing dampers should be used at the takeoff for each diffuser. Manual balancing dampers may not be required with ducts designed to Acutherm specifications.

Because Therma-Fuser diffusers control room temperature by sensing room air induced up the center of the space, care should be taken not to disturb room air induction and entrainment. For example, location next to walls or dropped lights results in the reflection of primary air back at the Therma-Fuser diffuser. Avoid this with a three-way blow pattern or relocate either the Therma-Fuser diffuser or the light.

Acutherm has "how to" system design brochures for almost every ducted air system. For specific recommendations refer to the brochure for your system.

GUIDE SPECIFICATION

Thermally powered variable air volume diffusers shall be Therma-Fuser model TF-HC manufactured by Acutherm, Hayward, CA. Each diffuser shall be a complete VAV terminal and thermostat self-contained in a nominal 2' x 2' diffuser. External wiring or pneumatics shall not be allowed.

The diffusers shall vary the supply air volume to provide both VAV heating and VAV cooling. They shall be thermally powered using two room temperature sensing thermostats and one changeover thermostat. The room temperature settings for heating and cooling shall be separately adjustable in the field by separately adjusting each of the two room thermostats.

One room temperature sensing thermostat shall sense room temperature and vary the supply air when cooling. The other room temperature sensing thermostat shall sense room temperature and vary the supply air when heating and shall be biased to offset room temperature stratification.

Each room sensing thermostat shall have a micrometer type temperature set point adjustment with an indicator that moves along a 70°F/21°C to 78°F/26°C temperature scale. Initial set point shall be factory set at 74°F/23°C.

The changeover thermostat shall be factory installed and adjusted to engage the heating mode when the supply air temperature rises above 80°F/27°C and return to the cooling mode when the supply air temperature falls below 68°F/20°C. The changeover mechanism shall not extend above the neck of the diffuser.

Each unit shall have four perimeter dampers to provide 66 linear inches of variable discharge area at the perimeter of the diffuser for maximum Coanda effect and to avoid dumping. Each module shall be factory tested.

The manufacturer shall warrant that the diffuser shall be free from defects in materials and workmanship for a period of ten years from date of shipment.

Each diffuser shall have a hinged appearance panel that can be unlatched and folded down

to hang allowing hands to be free for adjusting temperature set points. Instructions for the module shall be on the inside of the appearance panel.

DIMENSIONS

Inlet Designation	OD	
	Inches ±1/16	mm ±3
6	5 ¹⁵ / ₁₆	150
8	7 ¹⁵ / ₁₆	200
10	9 ¹⁵ / ₁₆	250
12	11 ¹⁵ / ₁₆	300

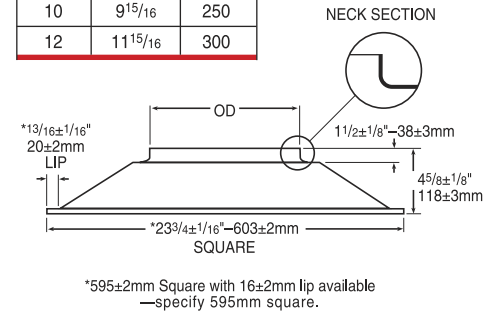

TEN YEAR WARRANTY

Acutherm warrants that its TF-HC Therma-Fuser diffusers, exclusive of any options and accessories (whether factory or field installed) shall be free from defects in material or workmanship for a period of ten (10) years from the date of shipment and agrees to repair or replace, at its option, any parts that fail during said ten (10) year period due to any such defects which would not have occurred had reasonable care been taken, provided that such parts have been inspected by Acutherm and found defective and provided the diffusers have been given normal and proper usage and all parts and controls remain unaltered. Acutherm makes NO WARRANTY OF MERCHANTABILITY OF PRODUCTS OR OF THEIR FITNESS FOR ANY PURPOSE OR ANY OTHER EXPRESS OR IMPLIED WARRANTY WHICH EXTENDS BEYOND THE LIMITED WARRANTY ABOVE. ACUTHERM'S LIABILITY FOR ANY AND ALL LOSSES AND DAMAGES RESULTING FROM DEFECTS SHALL IN NO EVENT EXCEED THE COST OF REPAIR OR REPLACEMENT OF PARTS FOUND DEFECTIVE UPON EXAMINATION BY ACUTHERM. IN NO EVENT SHALL ACUTHERM BE LIABLE FOR INCIDENTAL, INDIRECT OR CONSEQUENTIAL DAMAGES OR DAMAGES FOR INJURY TO PERSONS OR PROPERTY. Acutherm shall not be responsible for freight to or from its plant in connection with the inspection, repair or replacement of parts under the terms of this limited warranty nor for cost or installation.



The Individual
Temperature Control People

1766 Sabre Street
Hayward, CA 94545

Tel: (510) 785-0510

Fax: (510) 785-2517

http://www.acutherm.com
e-mail: info@acutherm.com